

\*Außengewinde mit axialer O-Ring Abdichtung

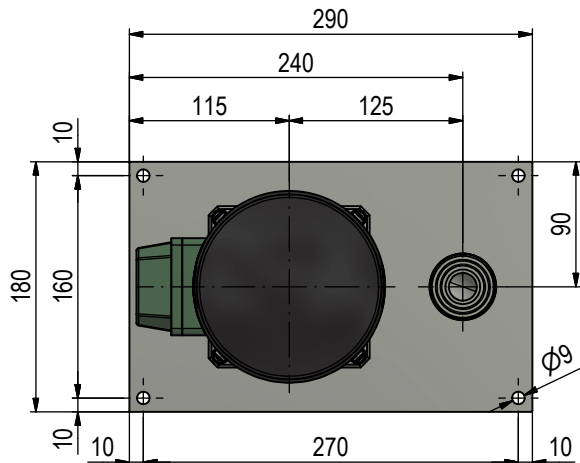

<p>Max-Eyth-Str. 13/17 D-74532 Ilshofen-Eckartshausen          Telefon: 07904 / 9715-0 Telefax: 07904 / 9715-30          e-mail: info@sager-mack.com          http://www.sager-mack.com</p>	Projektionsmethode 		Benennung <b>Kunststoff-Tauchpumpe / plastic immersion pump</b> SM-32-0.37KW-2p / Eintauchtiefe 270	
	Bearb.	Datum	Name	
	Gepr.			
Schutzvermerk ISO 16016 beachten Referred to protection notice ISO 16016	EDV-Nr. TPK-63_71-2-0.37-01.idw Druckdatum 16.05.19	Zeichn.-Nr. TPK-63/71-2-0.37-01	Rev. -	Blatt 1 / 1