

Ansicht A

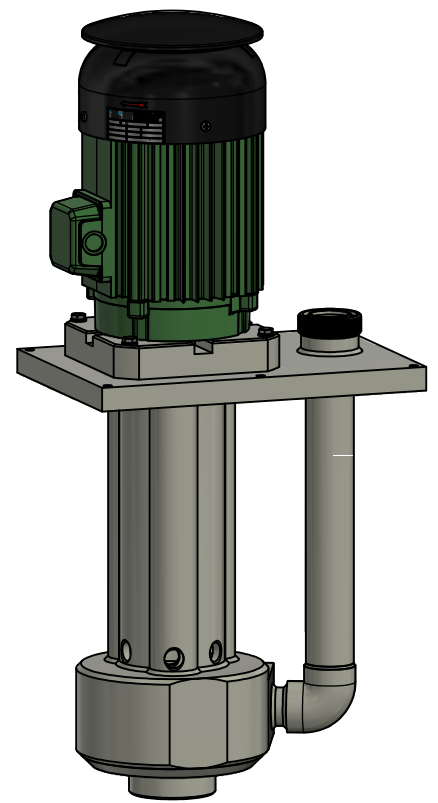

\*Außengewinde mit axialer O-Ring Abdichtung

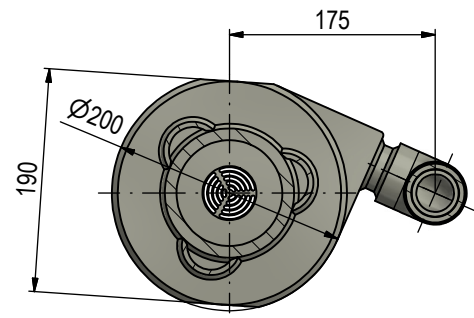
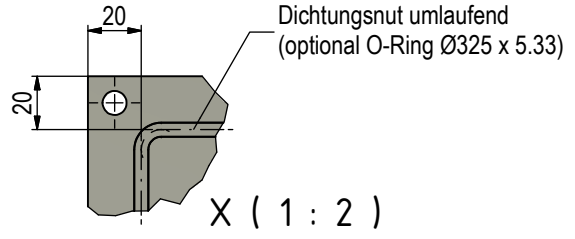
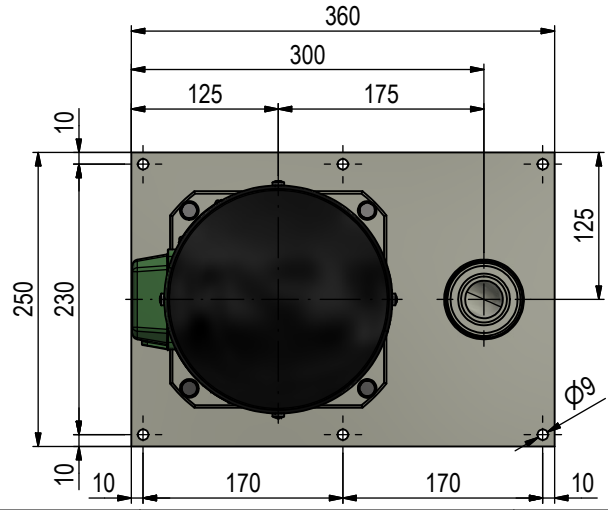

<p>           Max-Eyth-Str. 13/17 D-74532 Ilshofen-Eckartshausen            Telefon: 07904 / 9715 - 0 Telefax: 07904 / 9715 - 30            e-mail: info@sager-mack.com            http://www.sager-mack.com         </p>	Projektionsmethode 	Benennung <b>Kunststoff-Tauchpumpe / plastic immersion pump</b> SM-50-3.0KW-2p / HEFIE3 / 50Hz / Eintauchtiefe 400	
	Datum 23.01.2018	Name M.Bernard	Zeichn.-Nr. <b>TPK-100-2-3.0-02</b>
	Gepr. EDV-Nr. TPK-100-2-3.0-02.idw Druckdatum 23.01.18	Rev. - Blatt 1 / 1	
Schutzvermerk ISO 16016 beachten Referred to protection notice ISO 16016			